



Fiber Laser Chirped Pulse Amplifier

White Paper

PN 200-0200-00
Revision 1.2
January 2009

Overview

Fiber lasers offer advantages in maintaining stable operation over years, low total cost of ownership, and predictable operation in a small package. See our white paper “Fiber Laser Advantages”.

Ultrashort pulses are a new technology with many applications from sampling to non-thermal machining and surgery. Fiber lasers provide a stable and reliable mode-locked platform for generation of these pulses. These ultrashort pulse fiber lasers are the primary expertise of Calmar Laser.

Rather than higher average power, higher energy pulses are sometimes required for applications such as non-thermal machining or surgery. However, the small optical mode diameter in a fiber limits short pulse energy throughput due to nonlinear optical mechanisms. Although fiber lasers can generate Kilowatts of average laser power, sub-picosecond pulse energies are limited to 10s of μJ in commercial systems today. The Fiber Laser Chirped Pulse Amplifier (FLCPA) is one method for increasing the energy output of a fiber to many μJ and above.

The Chirped Pulse Amplifier is a method for amplifying short pulses by time stretching in such a way that the stretched pulse can later be recompressed back into a short pulse after the fiber amplifier system. The typical method for stretching is to “chirp” the short pulse, where different optical frequencies are delayed by different amounts of time to create a much longer pulse. The chirp stretching can be accomplished with a grating pair or a fiber grating. The typical method for recompressing a chirped pulse is a grating pair in free space at the exit aperture of the laser. This grating pair is the only free-space element of the FLCPA, which typically emits a beam in free space that’s guided to the target by free-space optics that can handle the high peak energy.

Although FLCPA have been demonstrated to generate 100s of μJ of optical pulse energy in scientific experiments, current commercial FLCPAs are in the 10 μJ range. With a pulse rate of 100s of KHz, overall FLCPA produce an average power of several Watts of high energy sub-picosecond pulses.

The Seed Laser

The Chirped Pulse Amplifier must be seeded by a high quality femtosecond source pulse. Calmar Laser’s femtosecond laser sources are passively mode-locked fiber lasers (FPL - femtosecond pulsed laser). Passive mode-locking makes these lasers easier to operate than actively mode-locked lasers, as no external RF clock signal is required, and little or no warm-up time is needed. Temperature control is also less of an issue with passive mode-locked lasers.

Calmar Laser’s passively-mode-locked lasers produce pulses as short as 80 fs. Repetition rates are fixed in the range 10 - 100 MHz. The peak output power of a femtosecond laser is, of course, high due to the short pulse durations, and peak powers up to 10 KW can be achieved using an integrated fiber amplifier. Figure 1 shows a simplified schematic of a passively mode-locked fiber laser.

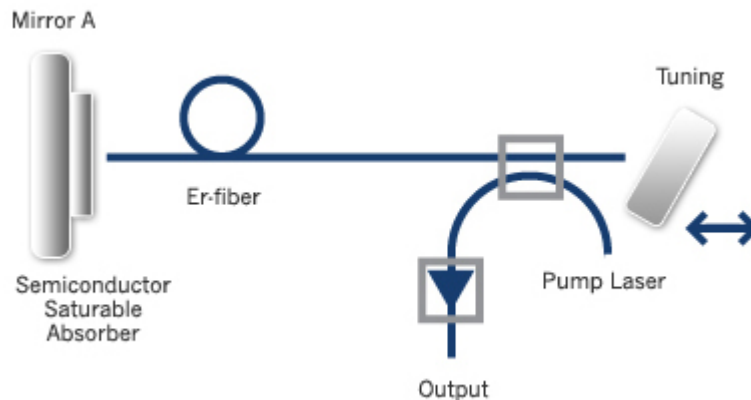

Figure 1 Schematic of Passive Mode-locked Fiber Laser

Since Calmar's fiber lasers are manufactured from discrete components, dispersive and non-linear effects can be carefully controlled. Pulse shape is transform-limited, and the pedestal is typically 20dB lower than the signal. Fiber lasers can make some of the highest quality short seed pulses at low energy.

Wavelength can be tuned from 1535 nm to 1560nm (C-band) or from 1030 to 1065 nm (1 μ m) with a simple adjustment from the front panel of the laser or fixed internally at one wavelength.

The capability to phase-lock the repetition rate to an external clock is available as an optional upgrade. In this scenario, a low jitter phase lock loop precisely tracks the laser repetition rate to an external clock. This feature is particularly useful for optical sampling applications.

Calmar's lasers are recognized for their stability, as demonstrated by their low timing jitter and low amplitude noise, thereby ensuring that the quality of the laser output meets even the most stringent test requirements.

The Chirped Pulse Amplifier

The high quality seed laser pulse is sent through an optical fiber amplifier system as shown in Figure 2.

Rugged fiber-only system

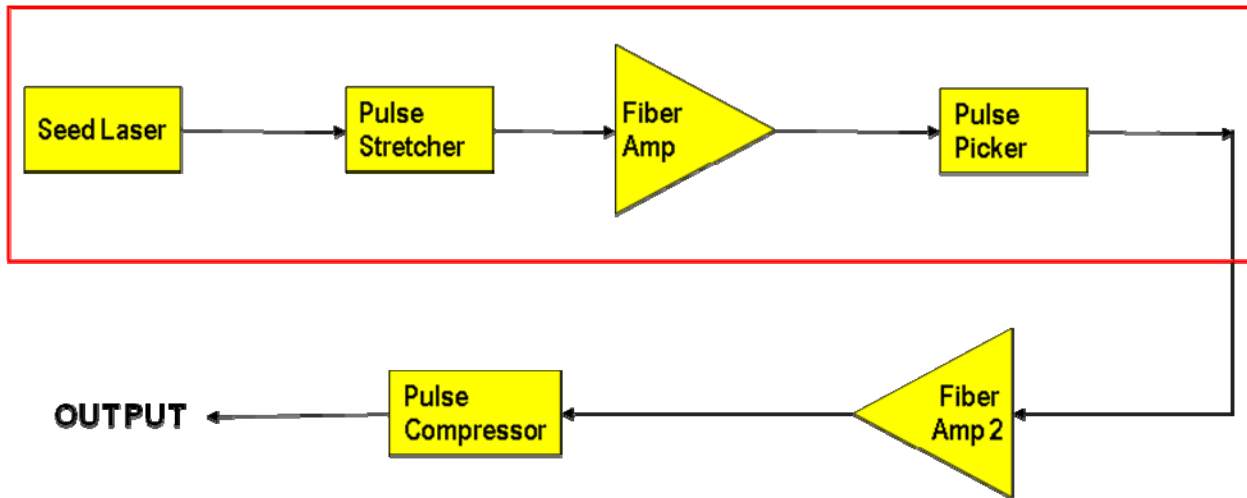

Figure 2 Fiber Laser Chirped Pulse Amplifier Diagram

But high-energy short-pulse light propagating in a small diameter fiber creates numerous nonlinear problems. First is the generation of self phase modulation. The light power itself will change the index of refraction in which it propagates. It causes, in many cases, undesirable effects such as optical spectral broadening and ill defined frequency chirp that prevents efficient pulse compression. A second problem is stimulated Raman scattering, or the creation of new light at shifted wavelengths via molecular vibration states in the glass fiber itself. Once triggered, it depletes the power in desired signal wavelengths, often limiting ultimate obtainable energy from the fiber system. These nonlinear effects can distort pulse shapes and modify the optical spectrum. Although the effects are usually detrimental, they can sometimes be useful in different manipulation, such as a Soliton wave, or for expanding the gain spectrum to get a shorter pulse. Ultrafast fiber lasers are dominated by nonlinear optical effects, which is rare in the free-space optical world. Fortunately, Calmar knows how to deal with the effects and with proper engineering can use nonlinear optical effects to advantage in laser systems.

As the peak power of the light increases, the nonlinear effects become stronger. Several methods are used to lower the peak intensity effects, to allow more pulse energy to be handled. First, the short pulse is spread out in time by frequency, or chirped. A typical method uses a diffraction grating pair, although fiber counterparts exist. After the pulse has traveled through the fiber optical system, the pulse can be recompressed back to an ultra-short pulse. This recompression may need to be done in free space if the peak pulse intensity is too high to allow further propagation in a fiber. Second, a larger diameter fiber core can be used. Recently, large mode aperture fibers have been developed that can increase the fiber area by an order of magnitude or more, while remaining single mode. Finally, new photonic band gap (PBG) fibers use an air core with much less nonlinear effects. These PBG fibers are just emerging and not yet reaching commercial use.

As the optical pulse energy increases, fiber damage may occur, usually at the entrance or exit of the fiber. However, this damage limit is usually well above the effects of nonlinear processes within the fiber.

In sum, fiber lasers can generate and handle very high average powers, in the kilowatts and above. But short pulses provide serious challenges. Today, the practical limit of sub-picosecond

pulse generation in a fiber is in the 10s of μJ , and then only with an external re-compressor. In order to avoid the undesirable nonlinear effects, a chirped pulse amplification method is typically used.

A chirped pulse amplification system consists in a seed laser, a pulse stretcher, amplifier chains, and a pulse compressor. First, to allow the pulse to be amplified without nonlinear optical effects from high peak power, the pulse is stretched by “chirping” via a free space grating pair or in-line methods such as dispersion engineered fiber stretcher or fiber grating. Calmar’s FLCPA adopts the in-line method for more robust CPA systems. The Pulse Picker reduces the pulse repetition rate from 10s of MHz to around 100 KHz, so as to give each pulse more energy for the same average pump power. If the pulse repetition rate goes much below 50 KHz, then amplified spontaneous emission (ASE) can draw energy from the pulse stream and lead to large continuous power emission between pulses. After pulse picking to a lower rate, the high energy Fiber Amp 2 is used. This last amplifier typically has a larger diameter single mode core to allow more peak power generation below the limit of nonlinear optical intensity effects, which can reduce pulse power with Raman scattering, lead to spectral changes, and affect the phase of the pulse so that recompression to a short pulse is not possible.

In spite of such efforts, a compromise is necessary between pulse energy and the amount of nonlinear optical effects that can be tolerated. First, because of the buildup of many nonlinear effects in the fiber, a pulse cannot be compressed completely back to an 80 fs pulse. Also, we show the effect of increasing output pulse energy on the pulse shape. At higher energies, optical nonlinearities cause the pulse to have a slightly wider pedestal. The trade off is one of a slightly affected pulse shape for the reliability of a fiber based CPA system.

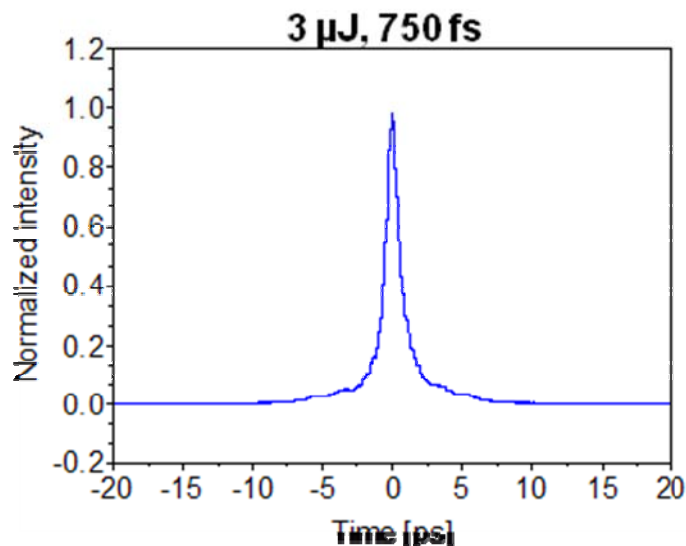

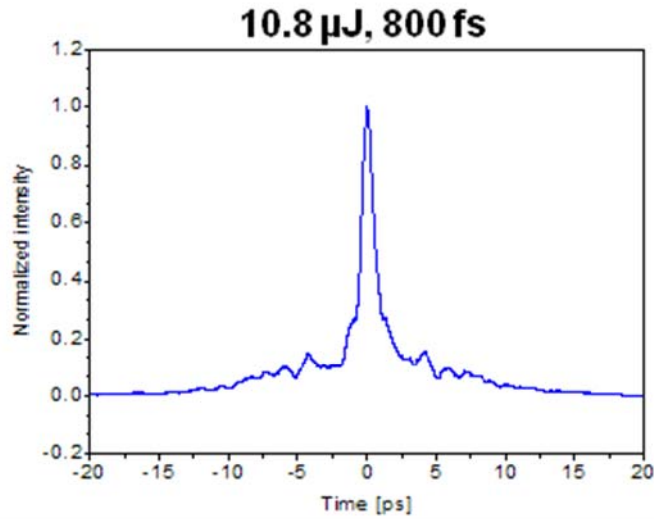

Figure 3 CPA Autocorrelation Trace at Two Pulse Energies

Gaussian versus Flat Top spectrum

Solid State lasers tend to use Gaussian spectrum and pulse shapes, which for a linear system provide the minimum bandwidth and lowest time-bandwidth product. In contrast, a fiber laser system will often choose a more flat top spectrum for improved pulse performance.

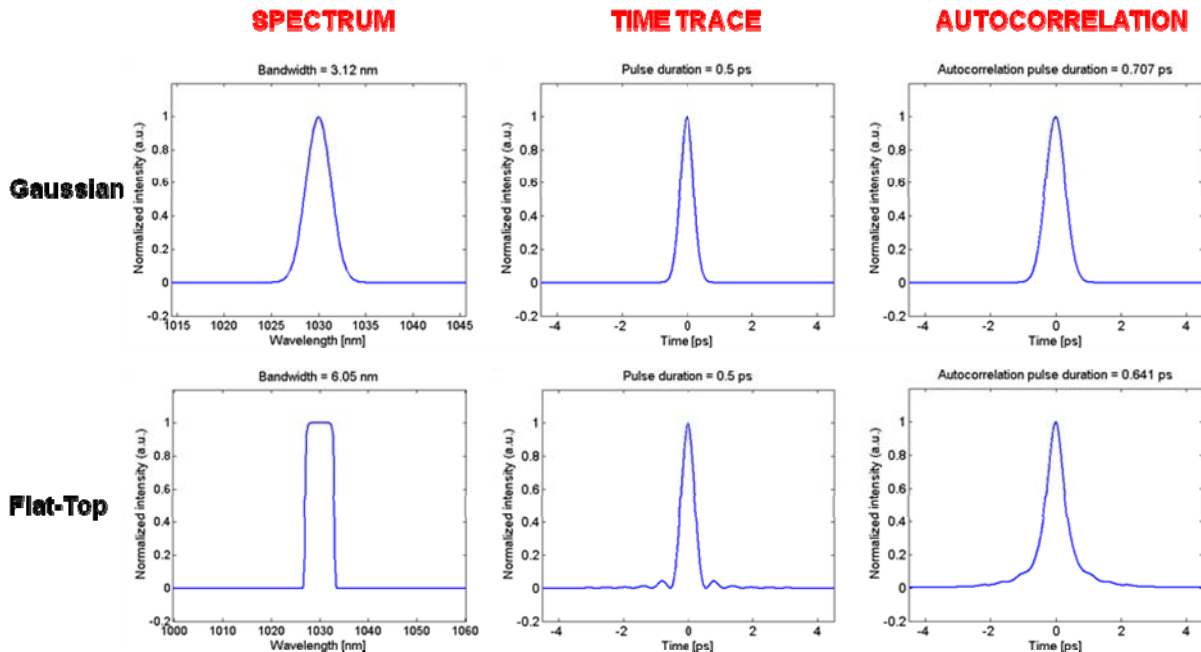

Figure 4 Comparison of Gaussian to Flat Top spectrum

As can be seen above, the Flat Top spectrum has a time bandwidth product that's almost double the Gaussian shape. One can understand as the Gaussian spectrum is more like a triangle where

the Flat Top spectrum is more a rectangle. However, what matters most in many real systems is the final pulse shape after all degradation processes.

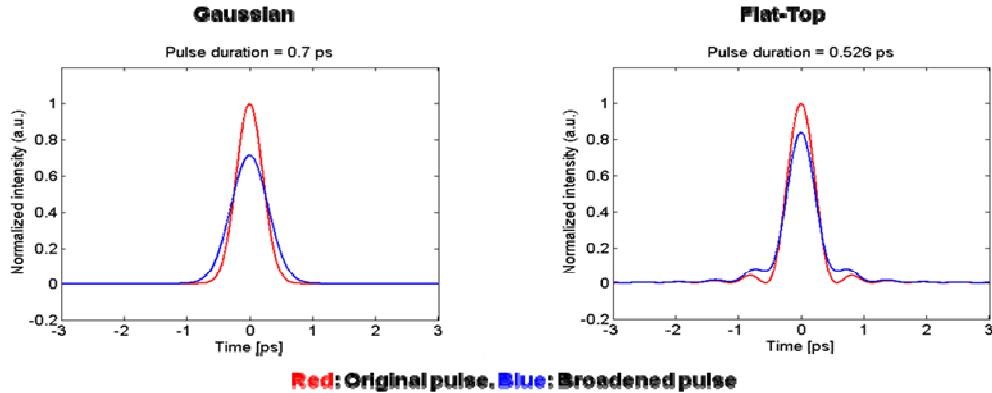

Figure 5 Effect of the same dispersion on Gaussian and Flat-Top spectral pulses. Whereas the Gaussian peak power drops 26%, the Flat-Top spectrum's peak power only drops 16%.

Because of the flat top spectrum's improved immunity to dispersion, and its ease of generation in fiber laser systems with easily saturated gain, it's the spectrum of choice for the FLCPA.

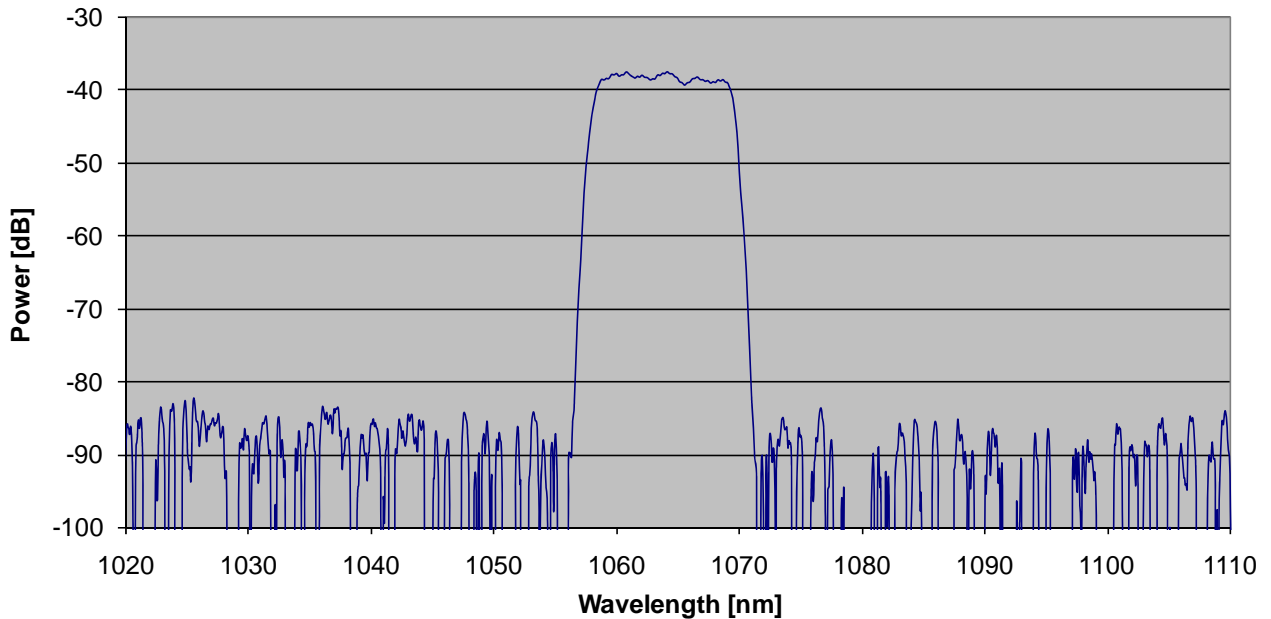

Figure 6 Spectrum of FLCPA output for 10.8 μ J pulse

Packaging

The FLCPA is usually preferred to be packaged into two boxes. The controller box handles the controls and electrical drives for the diode pump lasers, and monitors system performance in communication via a USB. The second optical box contains the fiber optical elements and can remain isolated on a laboratory table. The output of the CPA is in free space, so the optical box is designed for steady mounting on an optical table.

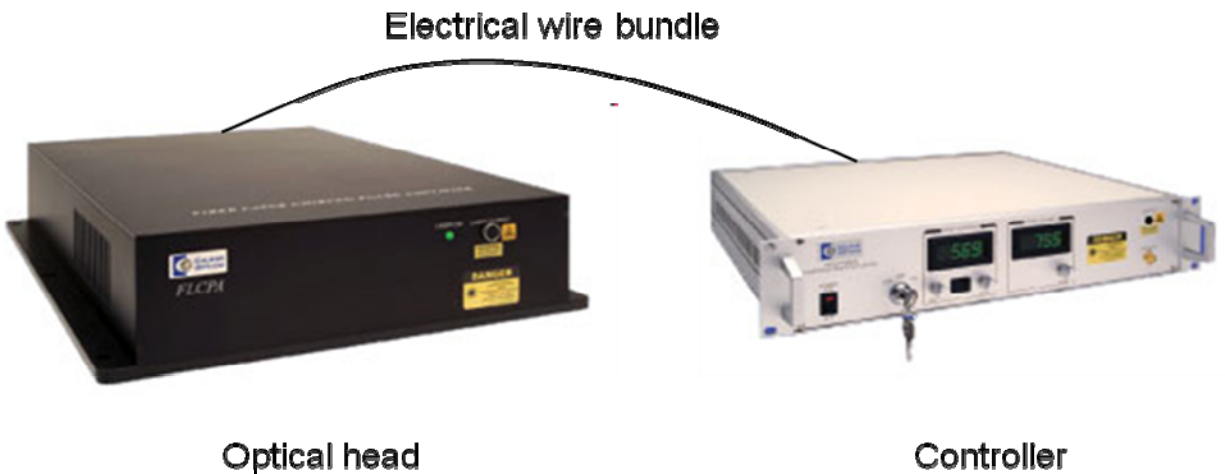

Figure 7 Typical Pulse Amplifier Package

If desired, Calmar can also package the entire FLCPA system into one closed box with USB interface for OEM integration.

Beam Performance

The following test results give an indication of the performance of Calmar's Femtosecond Fiber Lasers. Please note that the noise in the measured beam profile is caused by the sampling aliasing between the detector frequency (20 Hz) and the laser frequency (100 kHz).

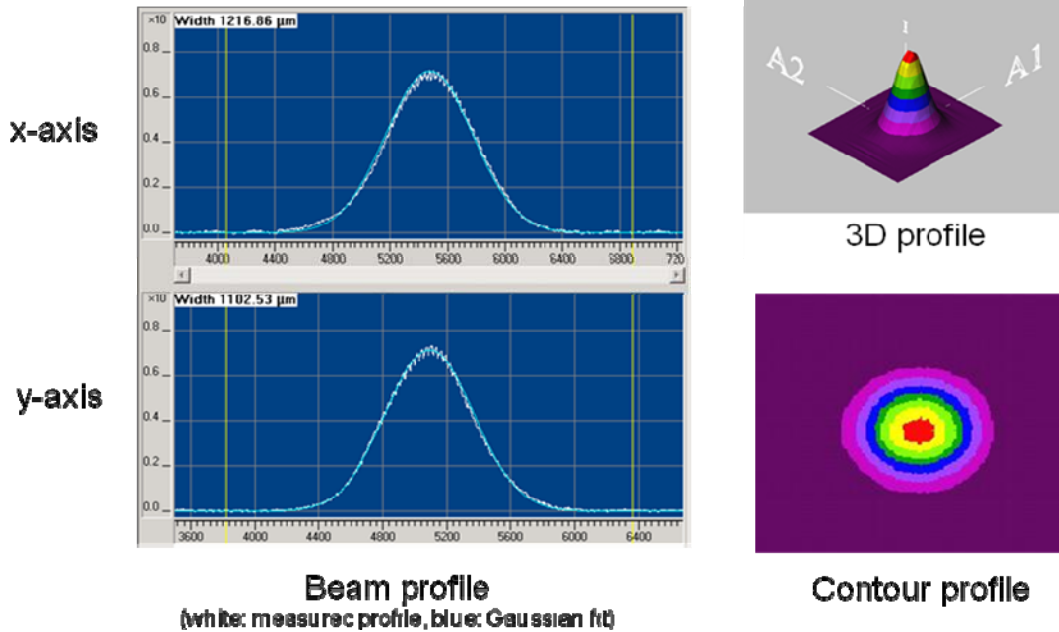
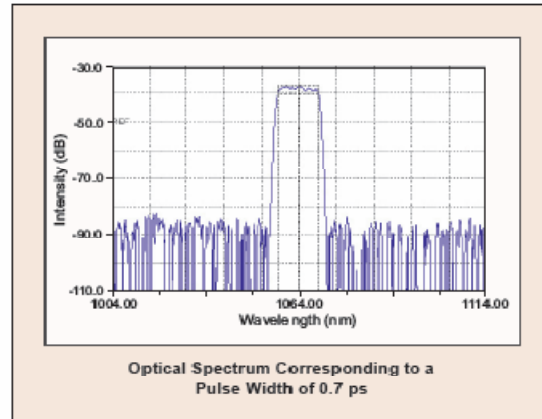
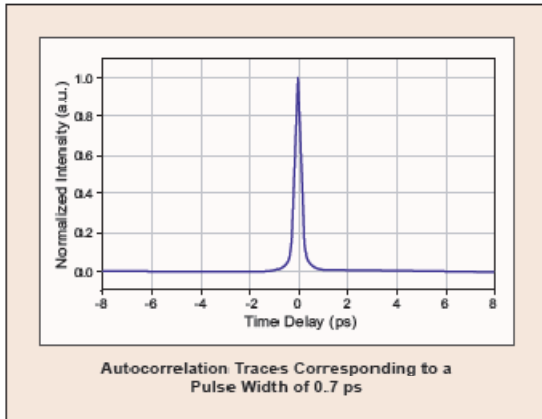

Figure 8 Beam Output Quality, $M^2 < 1.2$

Technical Specifications

Model Number	FLCPA-01C	FLCPA-02C	FLCPA-01U	FLCPA-02U	FLCPA-03U
Pulse Width (ps)*	<0.5	<0.7	<0.5	<0.7	<0.7
Central Wavelength (nm)	1545 ~ 1555 (selectable)		1030 ~ 1065 (selectable)		1030
Repetition Rate (kHz)	Up to 1500	Up to 500	Up to 1500	Up to 500	Up to 200
Pulse Energy (μJ)	1	3	1	3	10
Polarization Extinction Ratio	20 dB (typical)				
Output Beam (mm)	Free space, diameter 3 (typical), $M^2 < 1.2$				
Operating Temp (°C)	10 ~ 35				
Operating Voltage (VAC)	85 ~ 264				

* A sech_2 pulse shape (convolution factor of 0.65) is used to determine the pulse width for the second harmonic autocorrelation trace. Due to our continuous improvement program, specifications are subject to change without notice.



Applications

As laser pulse width reduces below a few picoseconds, energy deposited by the laser upon a surface cannot propagate a significant distance into the material during the time of the pulse. As such, the surface material turns into plasma that consumes the pulse energy and dissipates, leaving a clear cutting edge. Lack of time for thermal propagation assures the uncut material stays in original form without stress, fractures, melts, or other unwanted thermal processes.

For machining and surgical applications, a pulse width under 1 picosecond effectively works athermally. As such, the fiber laser CPA is an excellent candidate for such applications. Although a 0.5 to 0.7 picosecond pulse is slightly longer pulse than achievable by a solid state laser, the laser-material interaction is still dominated by ablation. Most importantly, the stability, reliability, compactness, lifetime, and total cost of ownership of a fiber laser system is clearly an advantage for commercial use.

As of today's laser specification, the application of Calmar's FLCPA may be categorized into three parts, which are bio-medical, precision material processing, and Terahertz/nonlinear optics study.

Bio-medical applications

Because subpicosecond pulses interact with material athermally, FLCPA is a best choice for precision cutting of benign material such as human tissue. Femtosecond lasers have long been used for optical tissue diagnostics and therapeutic surgery. Today they are also used for cutting cornea in the LASIK surgery process. On the other hand, high energy femtosecond pulses are used to manufacture nano-scale structures for bio-medical instrumentations. Such structures have been used as microfluidic channels for molecule separation.

Precision material processing

High energy subpicosecond pulses interact with material athermally and this fact gives a great advantage when micro-precision material processing is concerned. It is possible that femtosecond pulses can cut a smaller hole size than the wavelength, through intensity higher than ablation threshold and typical infrared femtosecond lasers can write fine structure with size

under several tens of nanometers. Compared to the well-known lithography method, femtosecond pulses are cost-effective in MEMs structuring. Femtosecond lasers provide a convenient, economical, and flexible way to fabricate three-dimensional biomedical patterns by varying the beam-scanning speed during ablation whereas clean room lithography requires a highly controlled environment and has limited capability for 3-D structuring.

Terahertz/Nonlinear optics application

Terahertz radiation is a preferred choice when non-destructive structural diagnosis is concerned. It can reveal the detailed contents of blocked scene through spectroscopic analysis, which is a very useful tool for security purposes. High energy femtosecond lasers are actually preferred choice for generating Terahertz sources and fiber laser provide reliable fundamental optical source. On the other hand, multiphoton imaging is an emerging field of application where high peak powered (e.g. femtosecond pulsed) laser are used for medical imaging of live cells. Compared to confocal single-photon imaging, multiphoton imaging provides much detailed scene of living cells with order of magnitude higher image resolution.

Beside those listed, a reliable high energy femtosecond source is now expanding its usages from academic research, through industry, to consumer medical markets and fiber laser can provide reliable source for various applications.

For more information on our Picosecond Fiber Laser series, Femtosecond Fiber Laser series, or any other Calmar products, please contact us.

E-mail:

sales@calmarlaser.com

Telephone:

(408) 733-7800, extension 110

Fax:

(408) 733-3800

Mail:

Calmar Laser
755 N. Pastoria Avenue
Sunnyvale
CA 94085